

LA SQUADRA
e i s v i t r i n e n



pure in quality

—
SELECTA
OUR BEAUTY



SELECTA

OUR BEAUTY



4

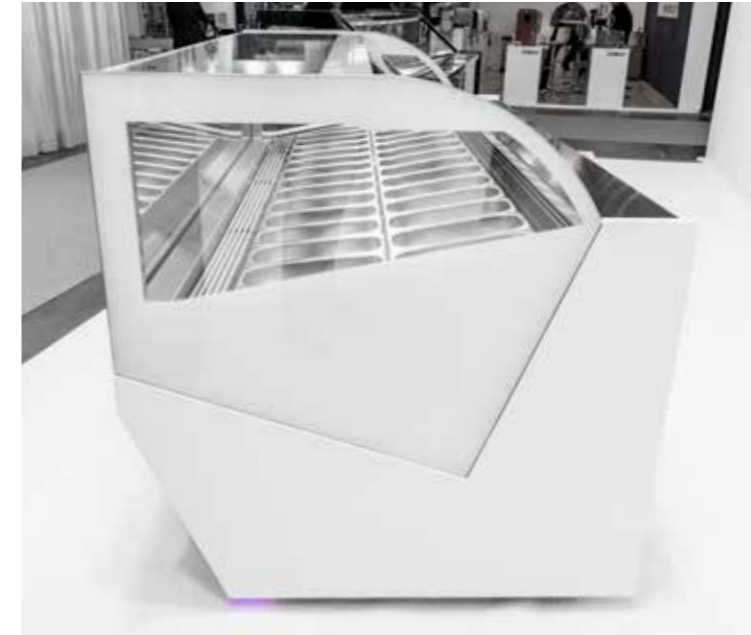

Strong Insulation up to 80 mm.
Starke Isolierung bis zu 80 mm.

Ice cream joy for the little ones: Display at eye level.
Eisfreude für die Kleinen: Präsentation auf Augenhöhe.

The SELECTA embodies the La Squadra design concept:
technical excellence without compromising on aesthetics.

Die SELECTA verkörpert das La Squadra Designkonzept:
Technische Exzellenz ohne ästhetische Abstriche.



5



MARISA
OUR STAR



MARISA

OUR STAR



10



Up to 32 ice cream flavours in one cabinet.
Bis 32 Eissorten in einer Vitrine.

The unique lift top glass are designed to easy open and clean.
Das Topglas hydraulisch klappbar.

Practical Classic with modern Design. Perfect viewing on the ice cream
Praktischer Klassiker mit modernem Design. Optimale Sicht auf das Speiseeis

Every detail of the MARISA is carefully composed, inside and out. Classic & Modern - the Perfect Combination.

Alle Innen - und Außendetails von Marisa sind genau durchdacht - Klassisch & Modern Die perfekte Kombination.



11





LUXURY

OUR ELEGANCE

The fusion of attractive design and technology, for our most demanding customers. We translated them into our most luxurious model: The LUXURY

Die Kombination von attraktivem Design und Technologie: für unsere anspruchsvollen Kunden. Wir haben diese in unser luxuriöses Modell übersetzt : LUXURY

LUXURY
OUR ELEGANCE



Linear air flow allows hills of ice cream.
Lineare Luftströmung ermöglicht große Eisberge

Double and heated front & side glasses.
Beheizte Isoliergläser.



Premium ice cream presentation : Double LED System
/Inclination / Reduced Height

Optimale Präsentation vom Speiseeis : Doppeltes LED
system /geneigte Ausstellfläche / niedrige Höhe



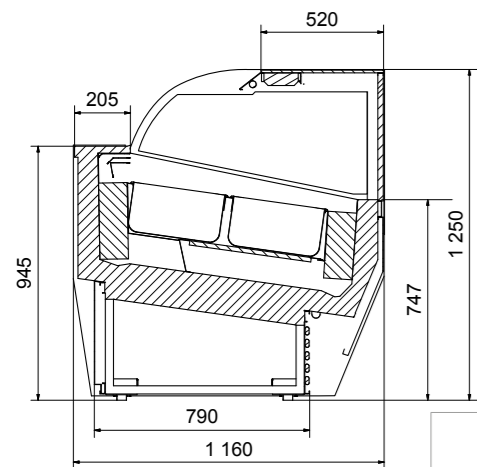

TECHNICAL SPECIFICATIONS SELECTA

SELECTA 12G ICE CREAM CABINET **SELECTA 16G** ICE CREAM CABINET **SELECTA 20G** ICE CREAM CABINET **SELECTA 24G** ICE CREAM CABINET **SELECTA 28G** ICE CREAM CABINET **SELECTA 32G** ICE CREAM CABINET

Size	1175 x 1160 x 1250 mm l x d x h		1506 x 1160 x 1250 m l x d x h		1830 x 1160 x 1250 mm l x d x h		2205 x 1160 x 1250 mm l x d x h		2530 x 1160 x 1250 mm l x d x h		2960 x 1160 x 1250 mm l x d x h	
Ice cream bins	12 360x165mm	8 360x250mm	16 360x165mm	10 360x250mm	20 360x165mm	12 360x250mm	24 360x165mm	16 360x250mm	28 360x165mm	18 360x250mm	32 360x165mm	22 360x250mm
Power suply	400 V / 3 / 50 Hz											
Total power	2100 W		2600 W		2900 W		3360 W		3780 W		3780 W	
Total power of defrosting	2400 W		3000 W		3430 W		4080 W		4580 W		4780 W	
Compressor power	1100 W		1450 W		1600 W		1860 W		2060 W		2240 W	
Net weight	270 kg		310 kg		370 kg		440 kg		500 kg		560 kg	
Refrigerant	R 455A											
Temperature range	-10°C / -22°C											
Climate class	35°C / RH 70%											

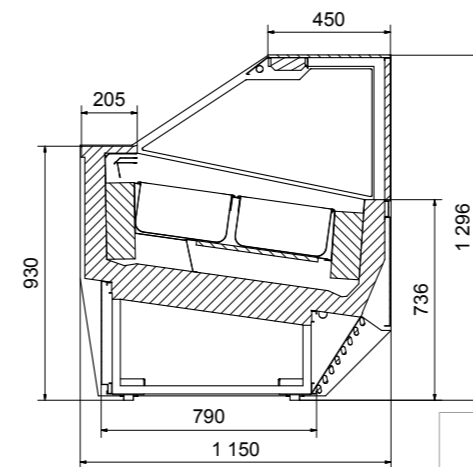

TECHNICAL SPECIFICATIONS MARISA

MARISA 12G ICE CREAM CABINET **MARISA 16G** ICE CREAM CABINET **MARISA 20G** ICE CREAM CABINET **MARISA 24G** ICE CREAM CABINET **MARISA 28G** ICE CREAM CABINET **MARISA 32G** ICE CREAM CABINET

Size	1175 x 1150 x 1290 mm l x d x h		1506 x 1150 x 1290 m l x d x h		1830 x 1150 x 1290 mm l x d x h		2205 x 1150 x 1290 mm l x d x h		2530 x 1150 x 1290 mm l x d x h		2960 x 1150 x 1290 mm l x d x h	
Ice cream bins	12 360x165mm	8 360x250mm	16 360x165mm	10 360x250mm	20 360x165mm	12 360x250mm	24 360x165mm	16 360x250mm	28 360x165mm	18 360x250mm	32 360x165mm	22 360x250mm
Power suply	400 V / 3 / 50 Hz											
Total power	2100 W		2600 W		2900 W		3360 W		3780 W		3780 W	
Total power of defrosting	2400 W		3000 W		3430 W		4080 W		4580 W		4780 W	
Compressor power	1100 W		1450 W		1600 W		1860 W		2060 W		2240 W	
Net weight	270 kg		310 kg		370 kg		440 kg		500 kg		560 kg	
Refrigerant	R 455A											
Temperature range	-10°C / -22°C											
Climate class	35°C / RH 70%											

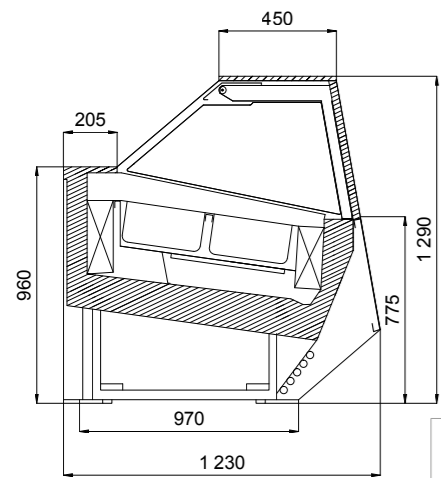

TECHNICAL SPECIFICATIONS

LUXURY

	LUXURY 12G ICE CREAM CABINET		LUXURY 16G ICE CREAM CABINET		LUXURY 20G ICE CREAM CABINET		LUXURY 24G ICE CREAM CABINET		LUXURY 28G ICE CREAM CABINET		LUXURY 32G ICE CREAM CABINET	
Size	1175 x 1230 x 1290 mm l x d x h		1506 x 1230 x 1290 m l x d x h		1830 x 1230 x 1290 mm l x d x h		2205 x 1230 x 1290 mm l x d x h		2530 x 1230 x 1290 mm l x d x h		2960 x 1230 x 1290 mm l x d x h	
Ice cream bins	12 360x165mm	8 360x250mm	16 360x165mm	10 360x250mm	20 360x165mm	12 360x250mm	24 360x165mm	16 360x250mm	28 360x165mm	18 360x250mm	32 360x165mm	22 360x250mm
Power supply	400 V / 3 / 50 Hz		400 V / 3 / 50 Hz		400 V / 3 / 50 Hz		400 V / 3 / 50 Hz		400 V / 3 / 50 Hz		400 V / 3 / 50 Hz	
Total power	2100 W		2600 W		2900 W		3360 W		3780 W		3780 W	
Total power of defrosting	2400 W		3000 W		3430 W		4080 W		4580 W		4780 W	
Compressor power	1100 W		1450 W		1600 W		1860 W		2060 W		2240 W	
Net weight	270 kg		310 kg		370 kg		440 kg		500 kg		560 kg	
Refrigerant	R 455A											
Temperature range	-10°C / -22°C											
Climate class	35°C / RH 70%											

FEATURES



PROFILES

Top design through small profiles

Topdesign durch schmale Profile



CURTAIN

Closing with curtain in the back

Hinten mit Rollo schliessbar



SPACE

Enough space on the smooth top

Genug Platz auf der oberen glatten Fläche



COMPRESSOR

Semi-hermetic Dorin Compressor

Semihermetischer Dorin Kompressor



EVAPORATORS

Large and coated Evaporators

Beschichtete Verdampfer mit großer Oberfläche



CONDENSER

Easy Clean Lid for Condenser

Easy Clean Deckel für den Verflüssiger

PASTRY CABINETS / KUCHENVITRINEN

Our pastry cabinets have the same design like our ice cream cabinets. All front and side glasses are double and airchambered. Slow ventilation through a big evaporator enables high level of moisture inside the cabinet.

Unsere Kuchenvitrinen haben das selbe Design wie die Eisvitrinen. Alle Front- und Seitengläser sind doppelt und isoliert. Eine langsame Umluftkühlung durch einen großen Verdampfer ermöglicht eine relativ hohe Luftfeuchtigkeit im Inneren der Vitrine.

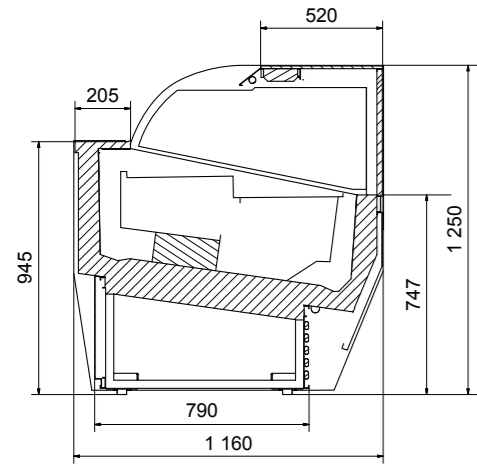

	SELECTA 12P PASTRY CABINET	SELECTA 16P PASTRY CABINET	SELECTA 20P PASTRY CABINET	SELECTA 24P PASTRY CABINET
Size	1175 x 1160 x 1250 mm l x d x h	1506 x 1160 x 1250 m l x d x h	1830 x 1160 x 1250 mm l x d x h	2205 x 1160 x 1250 mm l x d x h
Power suply	230 V / 1 / 50 Hz	230 V / 1 / 50 Hz	230 V / 1 / 50 Hz	230 V / 1 / 50 Hz
Total power	1000 W	1100 W	1210 W	1320 W
Net weight	230 kg	280 kg	350 kg	400 kg
Refrigerant	R 455A			
Temperature range	+4°C / +8°C			

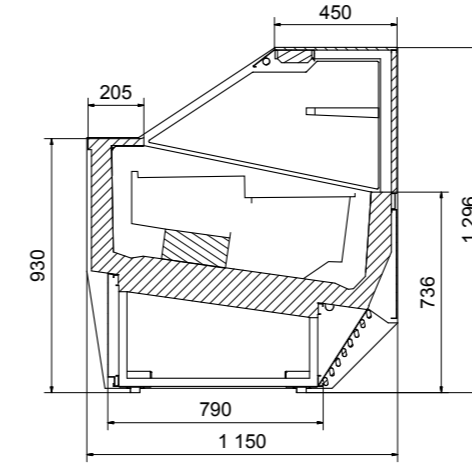

	MARISA 12P PASTRY CABINET	MARISA 16P PASTRY CABINET	MARISA 20P PASTRY CABINET	MARISA 24P PASTRY CABINET
Size	1175 x 1150 x 1290 mm l x d x h	1506 x 1150 x 1290 m l x d x h	1830 x 1150 x 1290 mm l x d x h	2205 x 1150 x 1290 mm l x d x h
Power suply	230 V / 1 / 50 Hz	230 V / 1 / 50 Hz	230 V / 1 / 50 Hz	230 V / 1 / 50 Hz
Total power	1000 W	1100 W	1210 W	1320 W
Net weight	230 kg	280 kg	350 kg	400 kg
Refrigerant	R 455A			
Temperature range	+4°C / +8°C			

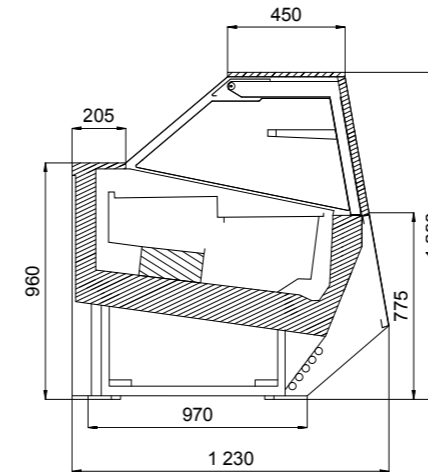

	LUXURY 12P PASTRY CABINET	LUXURY 16P PASTRY CABINET	LUXURY 20P PASTRY CABINET	LUXURY 24P PASTRY CABINET
Size	1175 x 1230 x 1290 mm l x d x h	1506 x 1230 x 1290 m l x d x h	1830 x 1230 x 1290 mm l x d x h	2205 x 1230 x 1290 mm l x d x h
Power suply	230 V / 1 / 50 Hz	230 V / 1 / 50 Hz	230 V / 1 / 50 Hz	230 V / 1 / 50 Hz
Total power	1000 W	1100 W	1210 W	1320 W
Net weight	230 kg	280 kg	350 kg	400 kg
Refrigerant	R 455A			
Temperature range	+4°C / +8°C			

MARISA 800

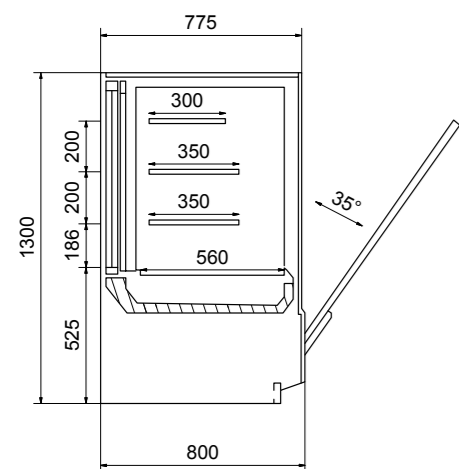

	MARISA 800-70 PASTRY CABINET	MARISA 800-100 PASTRY CABINET	MARISA 800-125 PASTRY CABINET	MARISA 800-150 PASTRY CABINET
Size	750 x 800 x 1302 mm l x d x h	1050 x 800 x 1302 m l x d x h	1300 x 800 x 1302 mm l x d x h	1550 x 800 x 1302 mm l x d x h
Power supply	230 V / 1 / 50 Hz	230 V / 1 / 50 Hz	230 V / 1 / 50 Hz	230 V / 1 / 50 Hz
Total power	600 W	700 W	850 W	1000 W
Net weight	110 kg	170 kg	220 kg	270 kg
Refrigerant	R 290			
Temperature range	+2°C / +8°C			



OUR STRATEGY / UNSERE STRATEGIE

PURE IN QUALITY

We are focusing like in the beginning on our main product : reliable and high quality icecream cabinets. The best marketing is for us to have satisfied customers.

EMOTION

Our gelato cabinets are not just machines, but furniture, which follows current trends and causes emotional reactions.

COURAGE

Is needed to export gelato cabinets to more than 60 countries all over the world ! You will find our cabinets in England, Germany and Norway but also as far away as the Philippines, South Africa, India and Australia. The continuous growth of our company confirms the confidence of our customers.

Pure Qualität

Wir konzentrieren uns nachwievor auf unser Hauptprodukt : eine verlässliche und qualitativ hochwertige Eisvitrine. Unser bester Marketing verstehen wir, zufriedene Kunden zu haben.

Emotion

Unsere Eisvitrinen sind nicht einfach Maschinen. Sie sind Einrichtungsgegenstände, die den aktuellen Trends unterworfen sind und Emotionen auslösen. Aus diesem Grund müssen Sie unseren höchsten Ansprüchen gerecht werden.

Mut

Man muss mutig sein, um Eisvitrinen in 60 Länder zu exportieren! Unsere Eisvitrinen stehen von Philippinen bis nach Norwegen, in Südafrika, Indien und in Australien ebenso wie in Deutschland oder England. Das kontinuierliche Wachstum bestätigt das Vertrauen unserer Kunden.



LA SQUADRA
e i s v i t r i n e n



LEDRA, s.r.o.

Headquarters / Hauptsitz:

Farská 42
949 01 Nitra
Slovakia

Factory / Fabrik:

Hlavná 1246
951 35 Veľké Zálužie
Slovakia

Tel: + 49 174 454 63 08
+ 421 915 752 882
+ 421 905 403 478

E-Mail: sales@lasquadra.de
www.lasquadra.de

Your Dealer / Ihr Händler:

